

Painted die-cast aluminum base composed of 4-spoke ballast and a painted extruded aluminum column with a square section. Equipped with a "Star" cross in die-cast aluminum.

STANDARD HEIGHTS

dimensions in millimeters

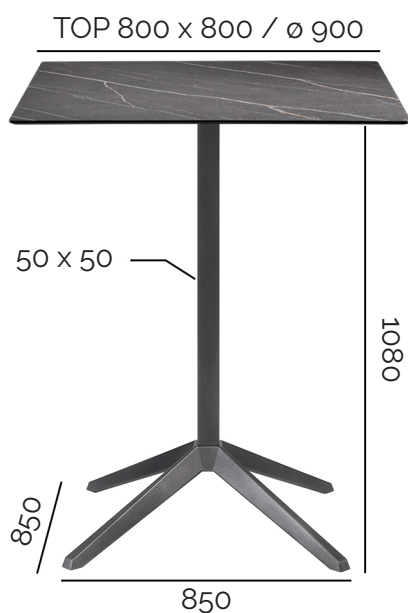

6,0 kg

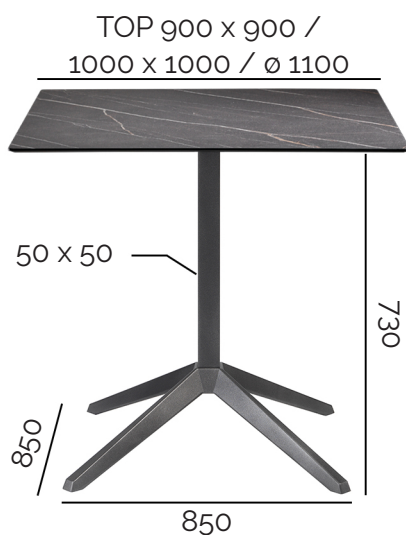

5,6 kg

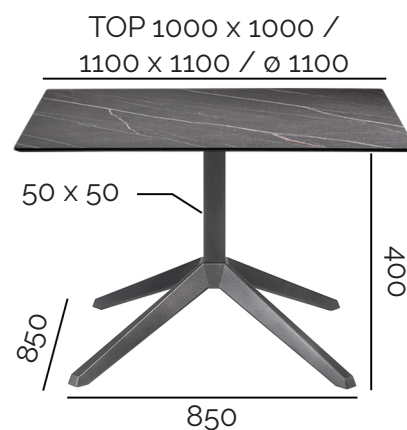

5,1 kg

Standard finishes



03. Orange peel effect black

Premium finishes

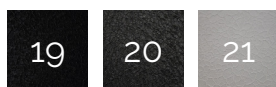

19. Damasco black, 20. Cracked black,
21. Cracked white

Special finishes



04. Wrinkle white, 05. Wrinkle cappuccino,
06. Wrinkle grey, 07. Graphite sand gray,
08. Graphite black, 09. Polished black gold,
10. Polished black silver, 11. Orange peel aluminum,
12. PF red, 13. Polished metallic silver,
15. Rust, 16. Corten



TECHNICAL DETAILS

- Die-cast painted aluminum base with epoxy dust
- Extruded painted aluminum column with epoxy dust
- "Star" cross in die-cast painted aluminum with epoxy dust
- 4 adjustable feet

EXTRAS

- Painting in any RAL color
- Exterior outdoor finishing (polyester painting) *
- Single base cardboard packaging

* see "[Warranty, cleaning and maintenance of the products, use and placement of the products](#)"

Aluminium Alloy 6063 (EN AW 6063 AlMg0,7Si)

According to EU directives: 2000/53/CE (ELV) - 2011/65/CE (RoHS II)

Aluminium-magnesium-silicium alloy

	THICKNESS				
	≤ 25	≤ 10	10 ≤ 25	≤ 10	10 ≤ 25
Physical Properties	T4	T5	T5	T6	T6
Mechanical Properties					
Ultimate tensile strenght Rm[N/mm ²]	130	175	160	215	195
Yield strenght Rp 0,2	65	130	110	170	160
Elongation A ₅	14	8	7	8	8
Hardness Brinell HB (information only)	50	65	65	75	75
Physical properties					
Density [kg/dm ³]	2,70	2,70	2,70	2,70	2,70
Module of elasticity [Gpa]	69	69	69	69	69
Electrical conductivity at 20 °C [m/Ω-mm ²]	33	33	33	33	33
Coefficient of thermal expansion [10 ⁻⁶ /K]	23,2	23,2	23,2	23,2	23,2
Thermal conductivity [w/m.K]	201	201	201	201	201
Melting point range ° C	615 ÷ 655	615 ÷ 655	615 ÷ 655	615 ÷ 655	615 ÷ 655
Processing Characteristics					
Machinability	++	++	++	++	+++
Dimensional Stability	+++	+++	+++	+++	+++
Erodability	++	++	++	++	+++
Weldability	++++	++++	++++	++++	++++
Polishability	+++	+++	++++	+++	++++
Anodizing Decorative	+++++	+++++	+++++	+++++	+++++
Anodizing Hard	+++++	+++++	+++++	+++++	+++++
Corrosion resistance (weather)	+++++	+++++	+++++	+++++	+++++
Corrosion resistance (seawater)	++++	++++	++++	++++	++++

Legend-ProcessingCharacteristics				
Excellent +++++	Good ++++	Accettable +++	Mediocre ++	Inadequate +